



CBUCK Engineering

Specialty Structural Engineering

CBUCK, Inc. Florida Certificate of Authorization # 8064

Evaluation Report of Streamline Roofing & Construction, Inc. "175 SL"

Metal Roof Assembly
for
Florida Product Approval
FL 7207.9 R1
Florida Building Code 2007
Per Rule 9B-72

Method: 1 - D
Category: Roofing
Sub - Category: Metal Roofing

Product: "175 SL" Roof Panel
Material: Copper
Panel Thickness: 16 oz.
Panel Width(s): 16"
Support Type: Wood Deck

Prepared for:
Streamline Roofing & Construction, Inc.
P.O. Box 2378
Tallahassee, Florida 32316

Prepared by:
James L. Buckner, P.E.
Florida Professional Engineer # 31242
Florida Evaluation ANE ID: 1916
Project Manager: Diana Galloway
Report No. 08-137-175-SL-16-C6W -ER
Date: 10 / 10 / 08

Contents:
Evaluation Report Pages 1 - 7

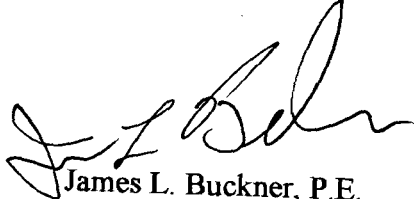

James L. Buckner, P.E.
Florida, P.E. #31242
10/23/08

C-BUCK Engineering

Specialty Structural Engineering

CBUCK, Inc. Florida Certificate of Authorization # 8064

Manufacturer:	Streamline Roofing & Construction, Inc.
Product Name:	“175 SL”
Product Category:	Roofing
Product Sub-Category	Metal Roofing
Compliance Method:	State Product Approval Rule 9B-72.070 (1) (d)
Panel Description:	“175 SL”, Copper, Snap-Lock, Standing Seam Roof Panel attached to Wood Deck.
Panel Material / Standards:	Material: Copper Minimum hardness: eighth-hard copper Corrosion Resistance: Material shall comply with the Florida Building Code (FBC), 2007 Section 1507.4.3.
Panel Dimension(s)	Thickness: 16 oz/sqft. minimum Width: 16” Maximum (Net Coverage Width) Rib Height: 1-3/4”
Support Type:	Wood Deck (Design of support system is not included in this evaluation)
Support Description:	<ul style="list-style-type: none">• 15/32” or greater plywood, or• Wood plank
Support Joints:	All butt and side joints shall be sealed by tape and/or with a one-part urethane caulk sealant per the tested condition. Self-adhered underlayment may be used as an acceptable alternative to sealing plywood joints. (Sealing the deck is part of the roof system structure resistance evaluation)
Slope Range:	Minimum slope shall comply with FBC 2007, including Sections 1507.4.2, 1504.7 and in accordance with the Manufacturers recommendations.
Underlayment:	Underlayment shall be per manufacturer’s guidelines as required in FBC Section 1507.4.5.
Insulation:	(Optional) Rigid Insulation Board, 3” maximum thickness and shall comply with ASTM C 578 per FBC Section 1508.2.
Fire Classification:	Fire Classification is outside the scope of Rule 9B-72, and is therefore not included in this evaluation. Additional approved substrates may be added for Fire Classification purposes.

C-BUCK Engineering

Specialty Structural Engineering

CBUCK, Inc. Florida Certificate of Authorization # 8064

**Attachment Component
Description:**

Roof Panel Clips

Material: Stainless Steel
Thickness: 18 gauge
Yield Strength: 45 ksi minimum
Nominal Dimension: 1-7/8" (tall) x 3-3/4" (long) x 1-3/8" (horizontal leg)
Corrosion Resistance: Per FBC Section 1506.7

Clip Fasteners

Type: Low profile head self-drilling screws
Material: Stainless Steel
Size: #10-16 x 1" (3/16 minimum penetration through deck)
Corrosion Resistance: Per FBC Section 1507.4.4 and 1506.6
Standard: Per ANSI/ASME B18.6.1

Installation:

Streamline "175 SL" Roof Panel Attached to Wood Deck:

- **Clip Spacing: 24" o.c.** maximum
(along the length of the panel)
- **TWO** Fasteners per Clip
- Rib Interlock: Snap-Lock
(Panel ribs shall be fully engaged to form an integral snap-lock.)
Minimum fastener penetration or embedment into wood deck, 7/8".

Design Uplift Pressure: - **52.5 PSF** (Safety Factor of 2:1)

Install the system in compliance with the attached installation method.
Refer to manufacturer's installation instructions as a supplemental guide for attachment.

C-BUCK Engineering

Specialty Structural Engineering

CBUCK, Inc. Florida Certificate of Authorization # 8064

- Quality Assurance:** The manufacturer has demonstrated compliance of roof panel products in accordance with the Florida Building Code and Rule 9B-72.070 (3) for manufacturing under a quality assurance program audited by an approved quality assurance entity through **Underwriter's Laboratories, Inc.** (FBC Organization #: QUA 1743)
- Performance Standards:** The product described herein has demonstrated compliance with:
- **UL580-94 – Test for Uplift Resistance of Roof Assemblies – with Revisions through February 1998.**
- Code Compliance:** The product described herein has demonstrated compliance with the Florida Building Code 2007, Section 1504.3.2.
- Evaluation Report Scope:** This product evaluation is limited to compliance with the structural wind load requirements of the Florida Building Code, as related to Rule 9B-72.
- System Limitations:** The maximum fastener spacing listed herein shall not be exceeded. All deck butt and side joints shall be sealed by tape and/or with a one-part urethane caulk sealant per the tested condition. The required design wind loads shall be determined for each project per FBC, 2007, Section 1609. Any rational analysis computations shall be prepared by a qualified design professional and in compliance with FBC 2007, Sections 104, 105, 106. This report does not evaluate use of this product in the High Velocity Hurricane Zone.
- Referenced Data:**
1. UL Uplift Class 90
By Underwriters Laboratories, Inc., (FBC Organization #CER ID: 1739)
UL File # TGKX.614
Based on UL580-94 (with February 1998 Revisions) Uplift Test
 2. Quality Assurance
Underwriters Laboratories, Inc. (FBC Organization #QUA ID:1743)
 3. Certification of Independence
By James L. Buckner, P.E. @ CBUCK Engineering
(FBC Organization# ANE ID: 1916)
 4. Engineering Analysis
By CBUCK Engineering
Report #C08-137, Dated: 10/19/08

C-BUCK Engineering

Specialty Structural Engineering

CBUCK, Inc. Florida Certificate of Authorization # 8064

Installation Method Streamline Roofing & Construction, Inc. "175 SL" (16 oz. Copper) Roof Panel Attached to Wood Deck

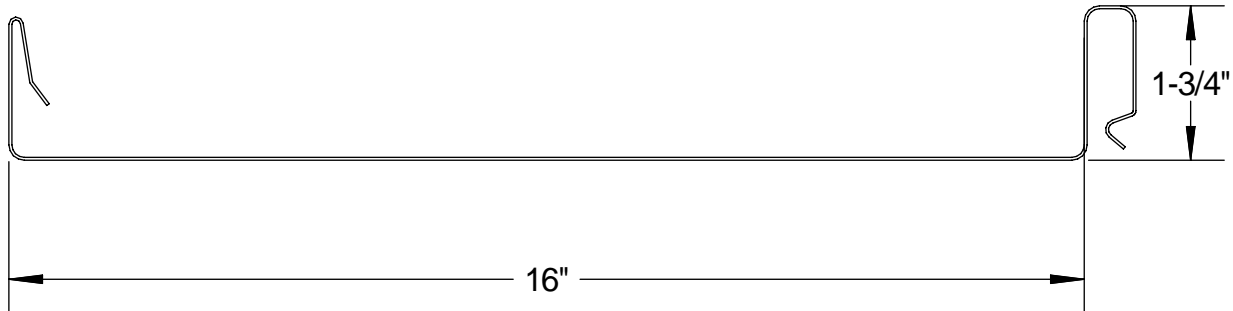

Panel Profile View

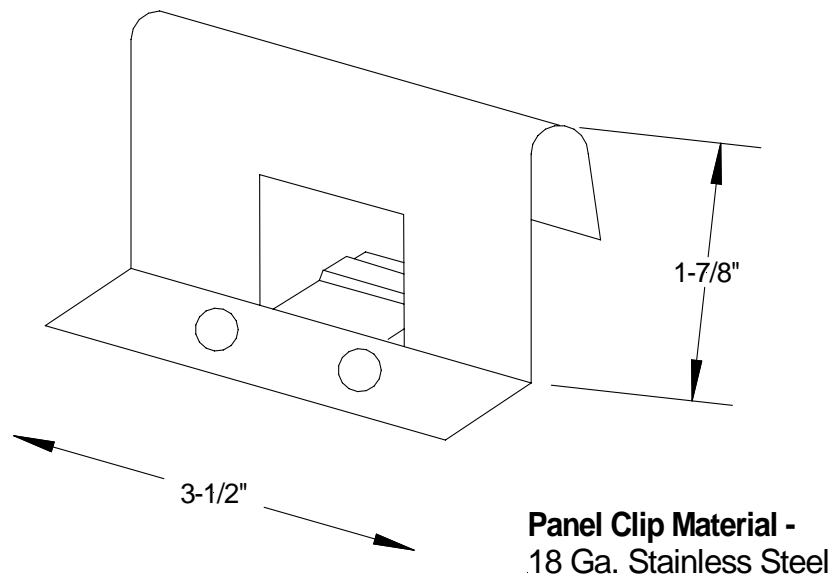

Panel Clip

C-BUCK Engineering

Specialty Structural Engineering

CBUCK, Inc. Florida Certificate of Authorization # 8064

Installation Method Streamline Roofing & Construction, Inc. "175 SL" (16 oz. Copper) Roof Panel Attached to Wood Deck

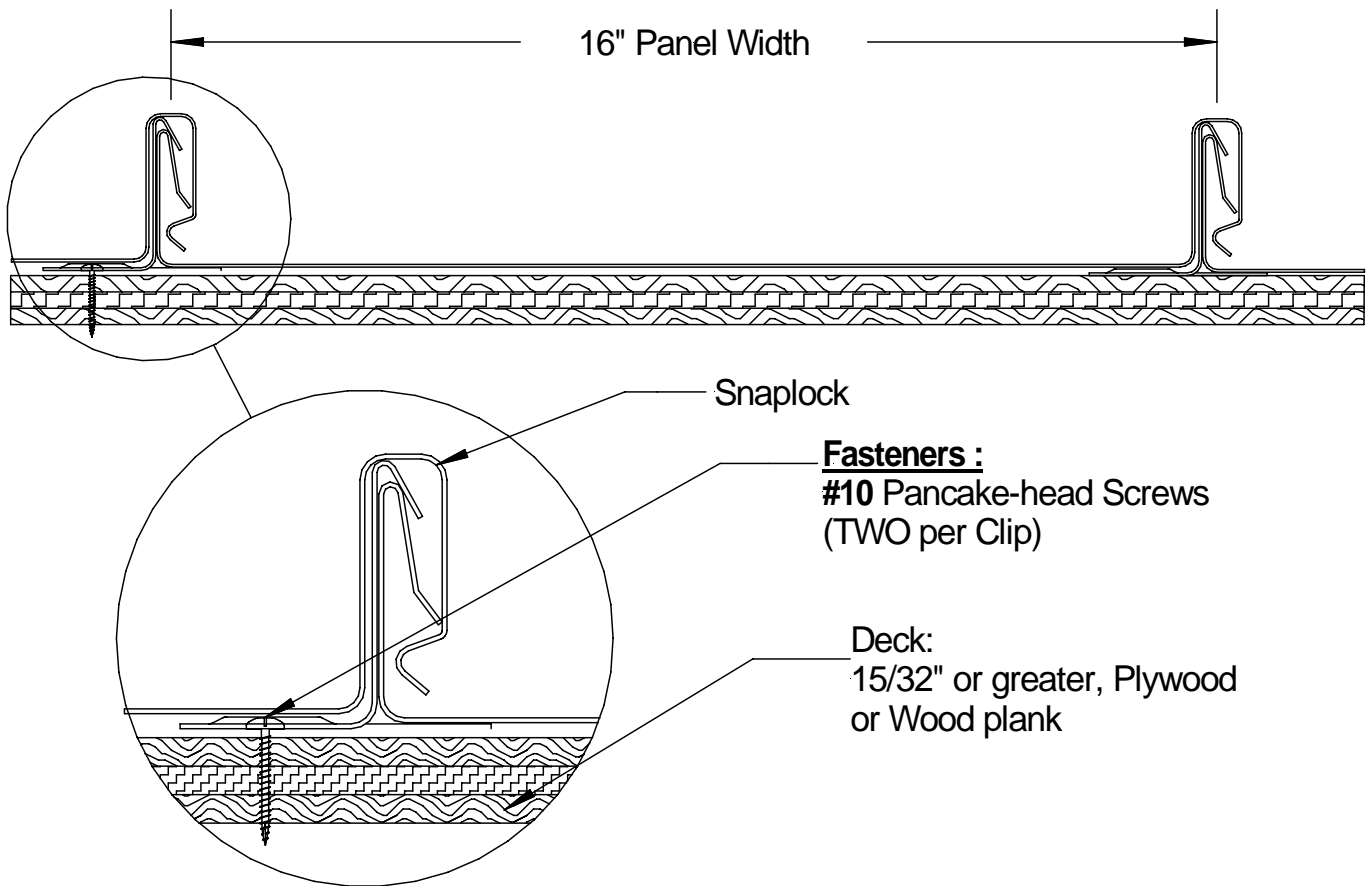

Typical Assembly Profile View

C-BUCK Engineering

Specialty Structural Engineering

CBUCK, Inc. Florida Certificate of Authorization # 8064

Installation Method Streamline Roofing & Construction, Inc. "175 SL" (16 oz. Copper) Roof Panel Attached to Wood Deck

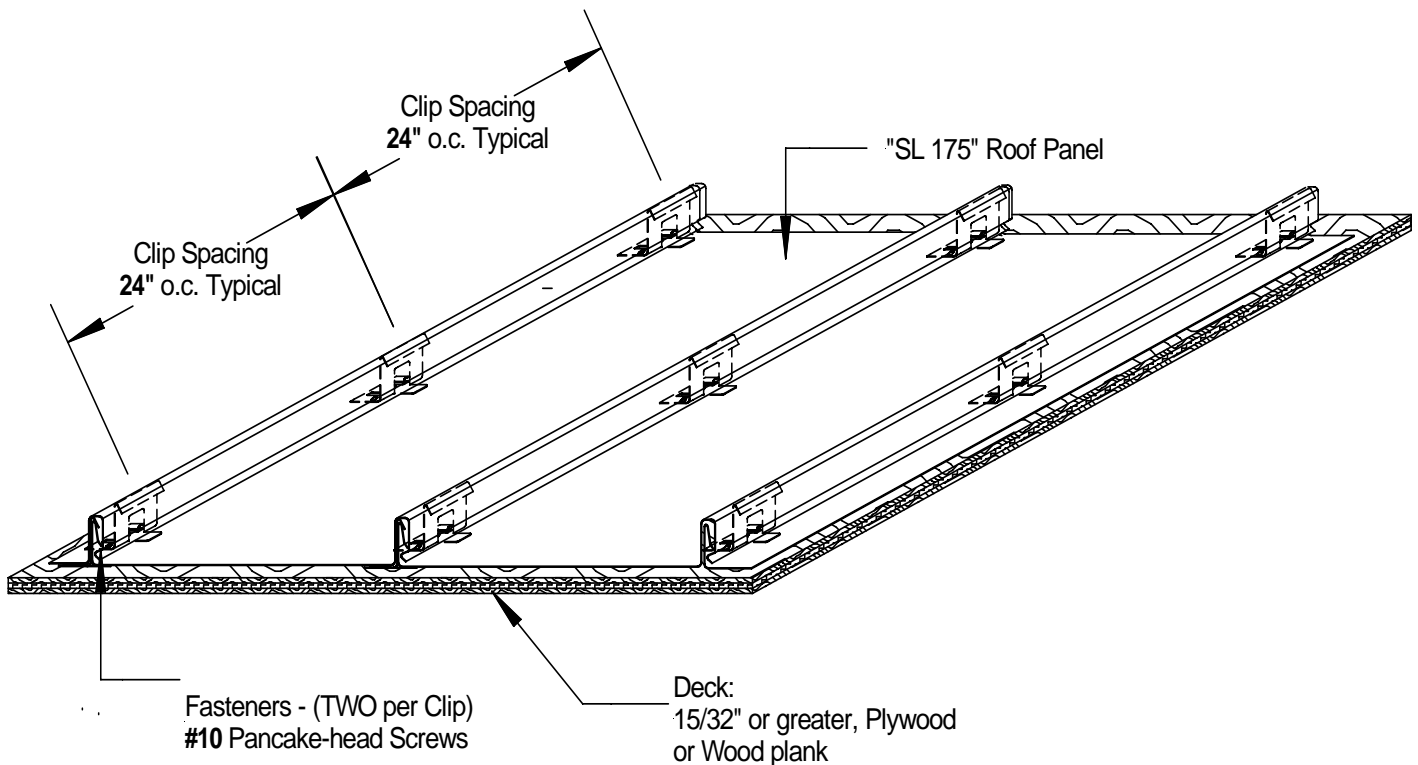

Typical Assembly Isometric View

Optional Insulation:

Rigid Insulation Board, 3" maximum thickness and shall comply with ASTM C 578 per FBC Section 1508.2.